

We make it *possible*

RAILWAY

ANTIVIBRATION & NOISE REDUCTION SYSTEMS



HUTCHINSON®

ALMOST 80 YEARS OF EXPERIENCE IN THE RAILWAY INDUSTRY

Since 1937, our railway division has developed significant experience in the design and manufacture of a full range of products for the railway industry.

The solutions we provide are custom-designed and tailored to meet our customers' requirements. Our goal is to offer flexibility, strong technical expertise and short lead times in order to match the market expectations. Our products are used in a wide range of rolling stocks, including locomotives, high-speed trains, regional trains, metro cars and light trains. The designs and solutions we provide are optimized to meet the high specific requirements of dynamic behaviour, long life and low maintenance.

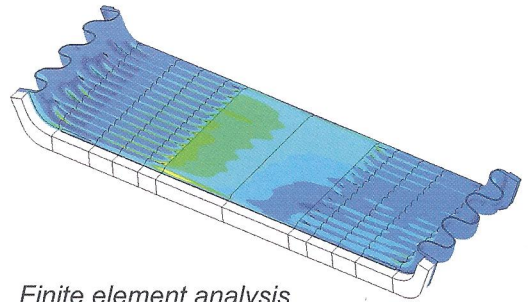

Finite element analysis

Test benches

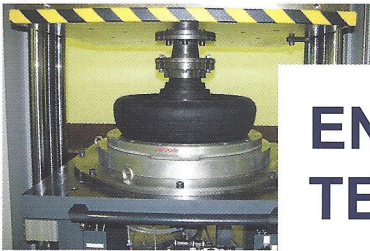

ENGINEERING / TESTING FACILITIES

With strong technical knowledge and innovative support from the HUTCHINSON Research Center, our customers benefit from an experienced team of engineers and designers who develop customized solutions for demanding applications.

Our capabilities include CAD Design (Autocad and Catia V5), Finite Element Analysis (FEA) and modelling, laboratory material for development of new compounds, static and dynamic testing facilities.

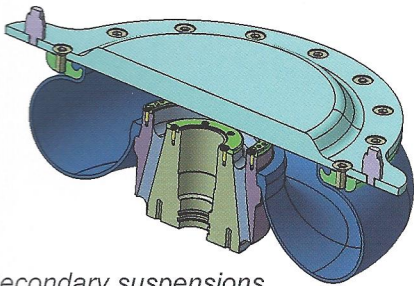

Secondary suspensions

LOW TEMPERATURE

With CRYSTALENE[®], elastomeric material for low stiffening at low temperature – until -50°C – HUTCHINSON is able to provide a full range of bearings and suspensions which allow to reach strong requirements without affecting main operating conditions on board, such as creep and fatigue behavior.

BOGIE EQUIPMENT



1 Primary suspensions

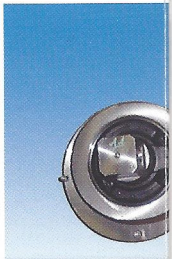
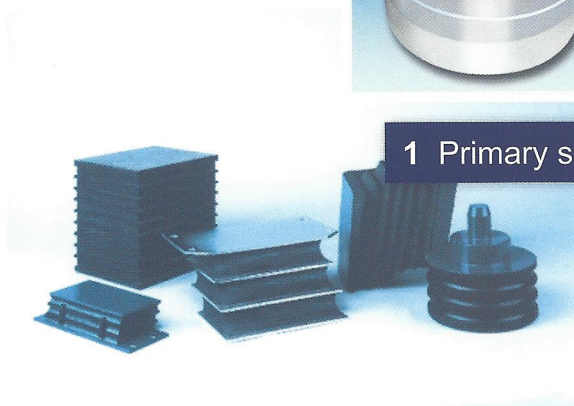

3 Elastic rods, elastic
and bushes

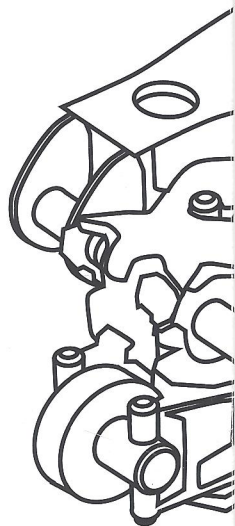

2 Secondary suspensions

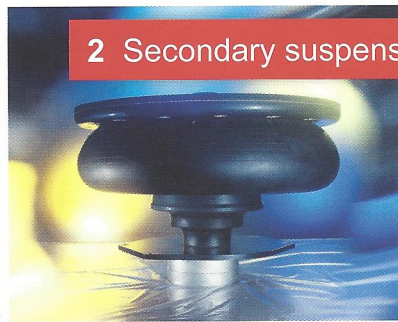

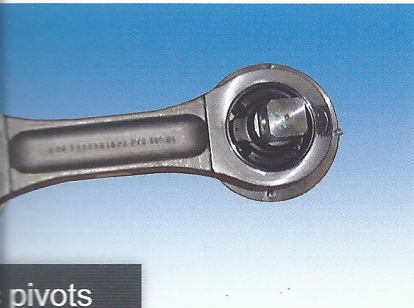

pivots

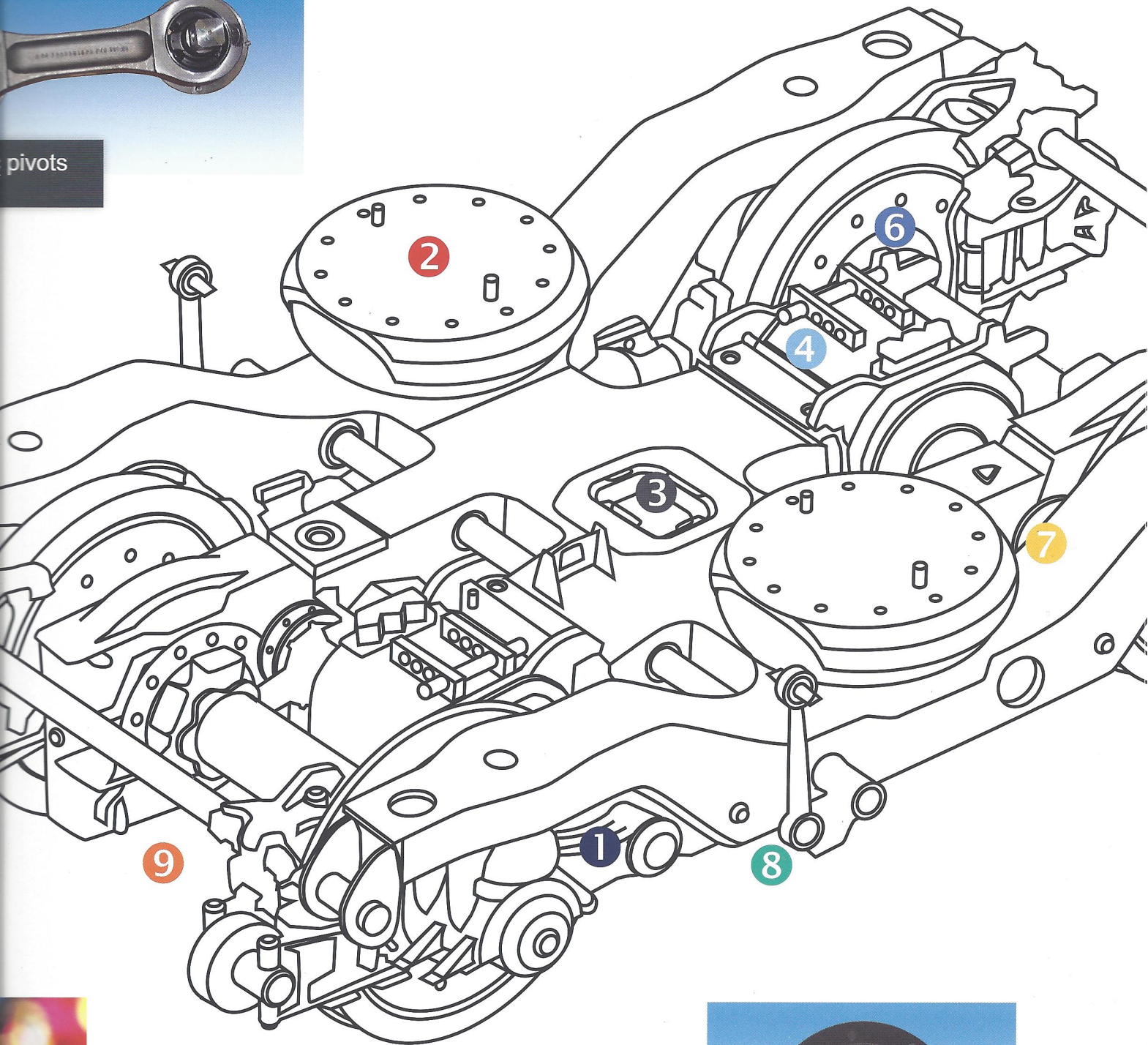

4 Suspensions for devices

Solutions adapted for equipment suspensions ensure vibration filtration.



5 Elastic wheels

To reduce harmful noise for passengers and equipment elements achieve the

6 Couplings



Special elastomer mixtures enable products to overcome high torsion stress, compression and shearing in severe environments.

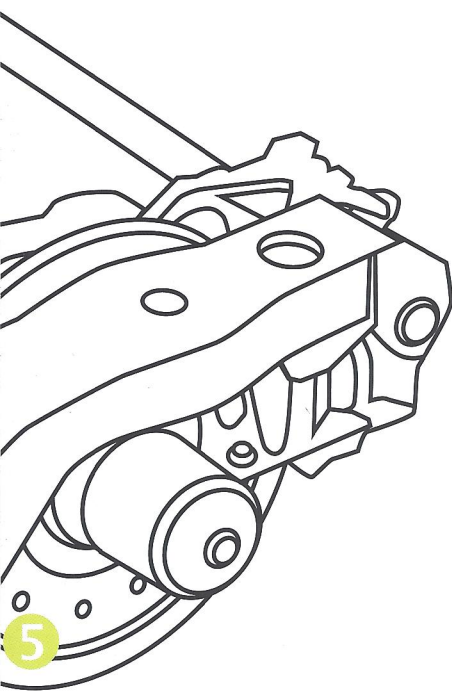

7 Stops



8 Anti-roll bar bushes

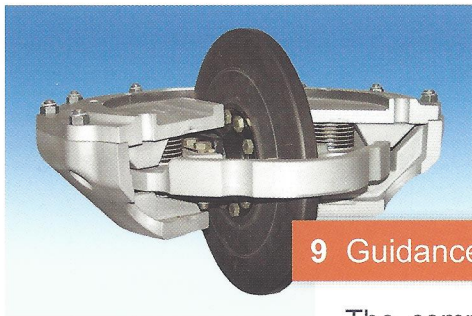

9 Guidance systems

The complete guidance system, including rubber components, is dedicated to specific light rail vehicle projects.

The guidance system ensures significant weight reduction, operational simplification and passenger comfort enhancement.

noise and vibration effects
for residents, the resilient
soundproofing of wheels.

GANGWAYS & INTER CAR BEARINGS

Intercommunication gangways

Allowing a high level of comfort and reliability, the intercommunication gangways are composed of adapted rubbers to meet fire, smoke and fatigue requirements.

Our main proposed solutions are :

- complete gangways for urban transport,
- aerodynamic profiles and sealing pads for high-speed trains,
- flanged UIC gangways for intercity trains.



Exhaust line packages

The complete exhaust line package includes silencers, expansion bellows, stabilizers, deck penetration mounts and wire mesh mounts. They are reliable and long lasting solutions in severe environmental conditions.

Inter car bearings

Our inter car bearings generate a significant reduction in maintenance costs.

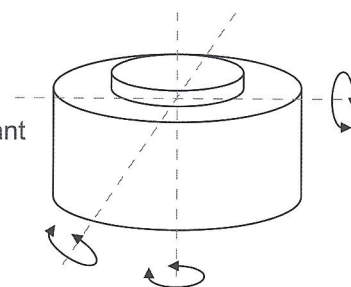

MAIN CUSTOMERS AND CURRENT PROJECTS



Bombardier : Régio2N, IDF, Talent2, AGC, EMU China.

SNCF : TGV, MI 2N, TER 2N.

Alstom : MI09, TGV, KZ8, Regiolis, TTNG, Iponan.

RATP : MP 05, MP89, MF2000.

Siemens : DESIRO Mainline, DESIRO Russia, VELARO Platform.

Other Customers : Bonatrans, Cfl, Crc Changchung, Deutsche Bahn Ag, Faiveley, Korail, Nedtrain, Oncf, Rotem, Sncb, Stadler Rail, Stm, Stc Mexico, Trenitalia.



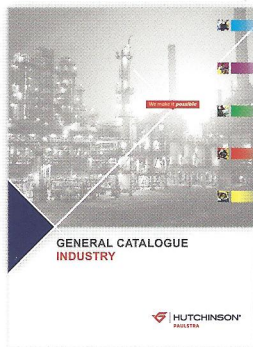

The railway division, as part of HUTCHINSON group and in combination with our world class capabilities, is able to optimize solutions to your vibration isolation problems.



As a world leader in vibration isolation technology, we can offer you a wide range of standard and custom-made products that are available worldwide.

WORLDWIDE OFFICES

Paulstra SNC - France

T. : +33 1 40 89 53 31
F. : +33 1 47 57 44 20
railcom.paulstra@hutchinson.fr
www.paulstra-vibrachoc.com

Stop-choc Ltd - UK

T. : +44 1 753 533223
F. : +44 1 753 693724
sales@stop-choc.co.uk
www.stopchoc.co.uk

Barry Controls - North America

T. : +1 508 417 7000
F. : +1 508 417 7224
info@barrycontrols.com
www.barrycontrols.com

Hutchinson Asia

T. : +86 512 8518 8298
F. : +86 512 8518 8292
railway@hutchinson-suzhou.cn
www.hutchinson-suzhou.cn

Vibrachoc - Spain

T. : +34 918 760 806
F. : +34 918 760 790
comercial@vibrachoc.es
www.vibrachoc.es

Hutchinson Stop-choc GmbH Germany

T. : +49 7 159 92 19 0
F. : +49 7 159 92 19 19
info@stop-choc.de
www.stop-choc.de

Techlam - France

T. : +33 3 89 75 66 67
F. : +33 3 89 39 89 62
info@techlam.org
www.techlam.org



HUTCHINSON®